

 **CORGI**

artigliO 50

artigliO 55



30"





L'**ARTIGLIO 50** e **ARTIGLIO 55** sono un'evoluzione dello smontagomme automatico a cui è stata applicata la tecnologia "**leva la leva**". Ideali per ruote vetture, SUV e veicoli commerciali fino a **30"**. Grazie alla tecnologia "Leva la Leva" è stata eliminata completamente e definitivamente la fatica fisica e il rischio legato al danneggiamento di cerchi e pneumatici particolarmente delicati o difficili, abbattendo contemporaneamente i tempi di lavoro su tutti i tipi di ruote di recente progettazione (dai low profile a tutti i run flat). L'attenta progettazione di ogni singolo componente ha poi permesso di ottenere un'attrezzatura dall'**ingombro ridotto**, **ergonomica** grazie alle altezze di lavoro e al posizionamento dei comandi, introducendo nuovi standard come il **gruppo stallonatore monobraccio** rotativo di 180° o il concetto "Easy To Fit" per una rapida ed efficace manutenzione. Un altro balzo in avanti per chi da 50 anni investe nelle proprie idee e le realizza.

Il modello **ARTIGLIO 55** nasce per l'utilizzo in mobilità coniugato a massima ergonomia ed efficienza: si lavora all'esterno del furgone, con lo smontagomme stabilmente appoggiato al terreno grazie alla traslazione assistita pneumaticamente.

*The **ARTIGLIO 50** and the **ARTIGLIO 55** are an evolution of the automatic tyre changer featuring the "**Leverless**" technology, the ideal for car, SUV and light trucks wheels up to **30"**. Thanks to the "Leva la Leva" technology all physical efforts and risks of damaging particularly delicate or demanding rims and tyres have been cut out. At the same time, working times on all latest-generation wheels (from low profile to all run flat types) are slashed. The meticulous design of every single component makes the **ARTIGLIO 50** compact, with **highly ergonomic working heights and control layouts**, introducing new standards such as the **single-arm bead breaker unit with 180° swing**, or the "Easy To Fit" concept for quick, effective maintenance. Yet another leap forward for a firm that has been investing in its ideas, and bringing them to fruition, for 50 years.*

*The **Artiglio 55** is conceived for mobile use with unparalleled ergonomics and efficiency: the operator works outside the van, with the tyre changer deployed pneumatically and placed securely on the ground.*

ARTIOLIO 50

ARTIOLIO 55



1 Gruppo stallonatore monobraccio automatico rotativo 180° (Patent Pending): preciso, ripetitivo e rapido nella procedura di stallonatura sui 2 fianchi **1** *Bead breaking unit with automatic single arm featuring 180° tilting (Patent Pending): quick, accurate, repetitive bead breaking on both sides of tyre*



● Movimento di apertura laterale ad azionamento pneumatico per consentire il posizionamento del braccio sul fianco inferiore

● *Pneumatically operated side-swing to locate the arm on the underside of the tyre*

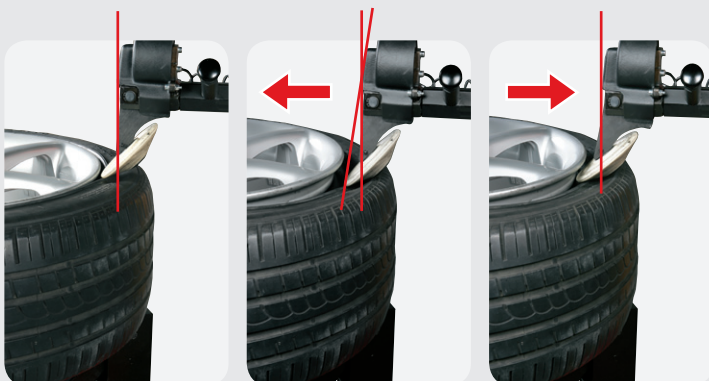

3 Nuovo sistema di penetrazione controllata che consente la stallonatura delle ruote più impegnative (Patent Pending)

3 *New controlled penetration system gives effective bead breaking on the most difficult wheels (Patent Pending)*

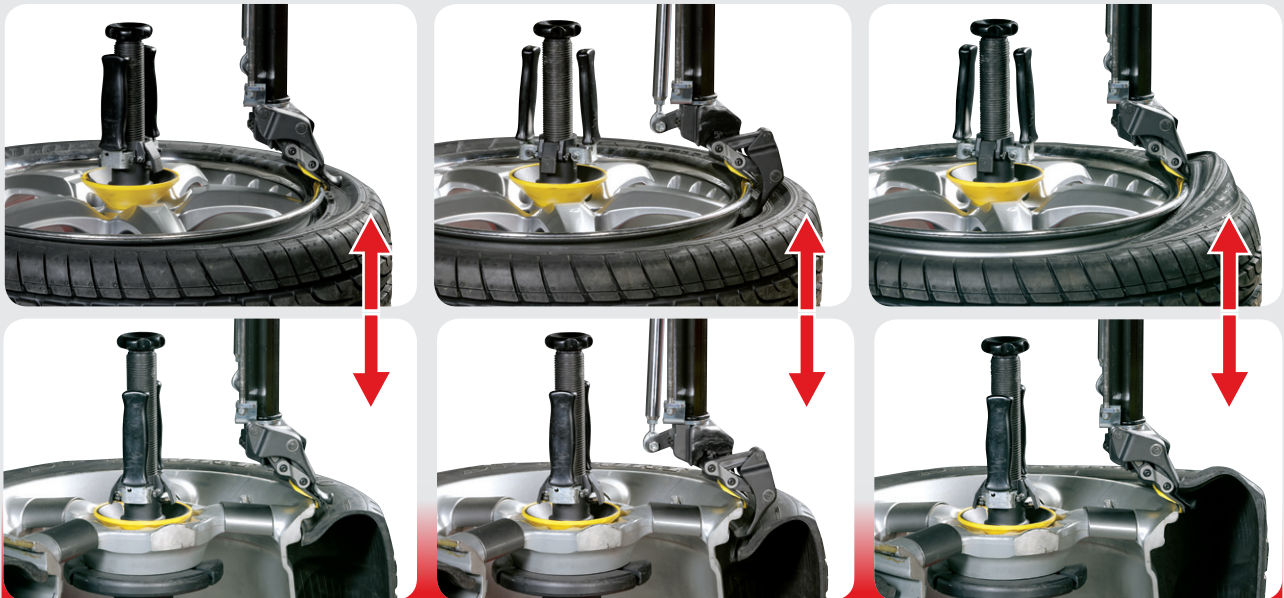

Procedura di smontaggio del tallone superiore - Top bead demounting procedure

Gruppo testata: 4 la procedura di smontaggio mantiene invariati i movimenti di lavoro eliminando in maniera definitiva lo sforzo fisico dell'operatore grazie alla tecnologia Leva la leva applicata alla torretta (Patent Pending) 4 la procedura di montaggio mantiene invariati i movimenti, la praticità, e la velocità d'esecuzione

Head unit: 4 the demounting procedure uses the same working movements but absolutely no effort is required from the operator thanks to the "Leva la leva" technology incorporated in the mount/demount head (Patent pending) 4 the mounting procedure is exactly as before, and just as quick and convenient



- Procedura standard di smontaggio del tallone inferiore con torretta
- Standard bottom bead demounting procedure with mount/demount head



- Procedura rapida con disco stallonatore (particolarmente indicata con fianchi duri) per lo smontaggio del tallone inferiore
- Rapid bottom bead demounting procedure with bead breaker disc (particularly useful with stiff sidewalls)



ARTIGLIO 50

ARTIGLIO 55

Procedura di montaggio del tallone superiore - Mounting the upper bead



- Con pinza
- With clamp



- Con premitallone (accessorio a richiesta)
- With bead pressing clamp (optional accessory)



- Con morsetto basculante (accessorio a richiesta)
- With mobile clamp (optional accessory)

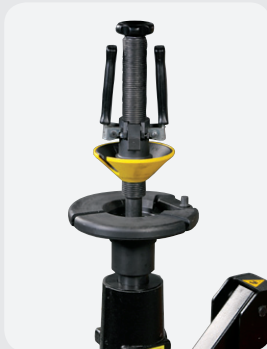
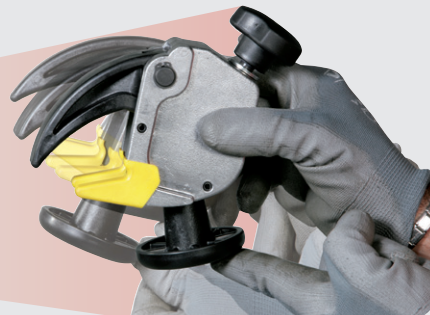

5 Autocentrante a platereello consente il bloccaggio sicuro e veloce della ruota e permette la stallonatura di entrambi i fianchi in una sola presa (senza bisogno di girare la ruota) **5** Axial mounting turntable allows quick, secure wheel clamping and bead breaking on both sides with no need to turn the wheel over (wheel is clamped on the machine just once)



- Motorizzazione con sistema intelligente motoinverter: la giusta coppia alla giusta velocità (7-18 RPM)
- Intelligent motoinverter drive system: the right torque at the right speed (7-18 RPM)



● Altezza di lavoro della macchina studiata per ottenere una perfetta ergonomia nei movimenti con tutti i tipi di ruote: Ideale per tutti gli operatori ● *Machine working height designed for perfect ergonomics with all kind of wheels: ideal for all operators.*

* eccezione per cerchi a canale rovescio - *except for reverse rims*

- Anello porta grasso regolabile
- Adjustable grease ring



- Tutti i comandi che controllano i movimenti della macchina si trovano in posizioni ergonomiche all'operatore
- *All machine movement controls are conveniently to hand for the operator*

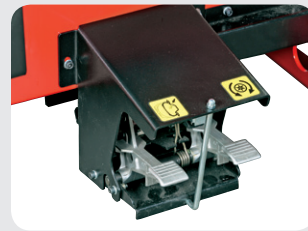
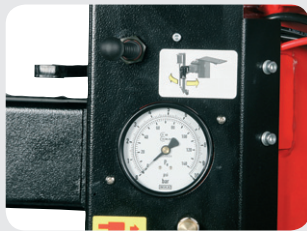

DOTAZIONE DI SERIE - STANDARD EQUIPMENT



ACCESSORI A RICHIESTA - ACCESSORIES ON REQUEST



Kit cerchi furgone
Pick-up rim kit



Flangia universale cerchi ciechi
Universal flange for closed rims



Flangia per ruote a canale rovescio
Reverse wheel flange



Kit per ruote pax system
Pax system kit



Kit telecamera + inflatron (ordinabile solo con la macchina)
Lower view camera and electronic inflating device (available with the machine only)



Kit intallamento rapido: TY System
TY system Kit



Sollevatore ergonomico consente di posizionare in maniera facile tutte le ruote sull'autocentrante (accessorio a richiesta)
Ergonomic wheel lift allows easy positioning of all wheels on the turntable (optional accessory)

artiglio 55

Movimento dello smontagomme **assistito pneumaticamente**.
Nessuna fatica e **tempi rapidissimi**
per far uscire e rientrare lo
smontagomme dal furgone.

***Pneumatically assisted tyre
changer movement.***
*Move the tyre changer out of and
back into the van **effortlessly and
quickly.***

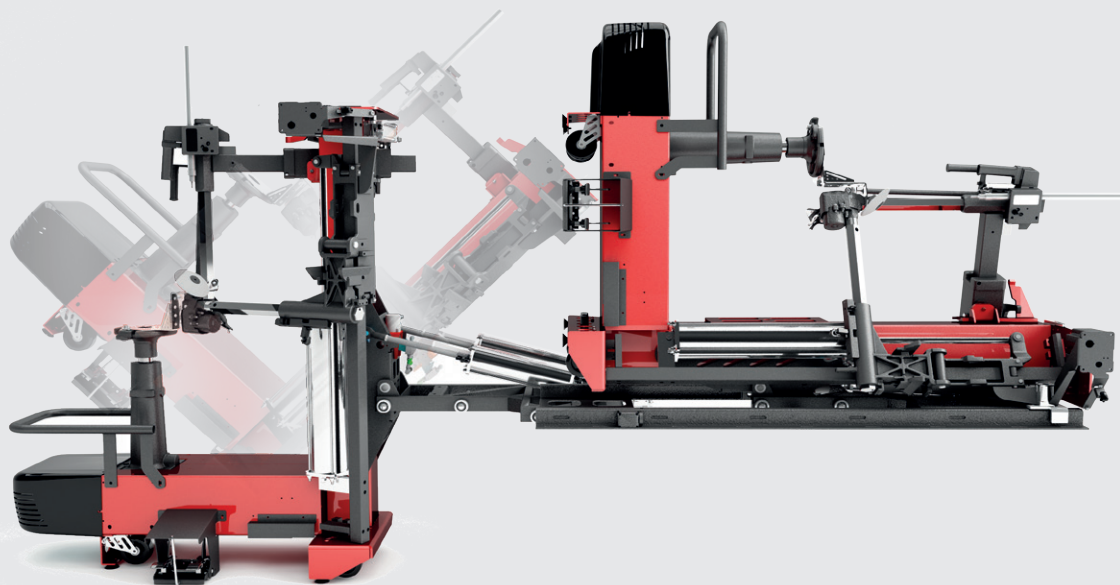
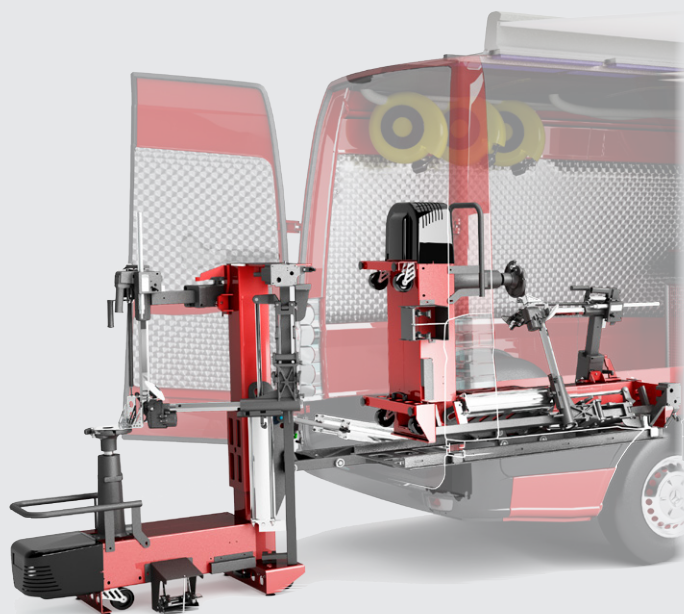

Ingombri / Dimensions ARTIGLIO 55

- Lunghezza massima (A): 1807 mm
- Larghezza massima (B): 821 mm
- Altezza massima (H): 1249 mm

Overall dimensions of ARTIGLIO 55:

- Maximum length (A): 1807 mm
- Maximum width (B): 821 mm
- Maximum height (H): 1249 mm

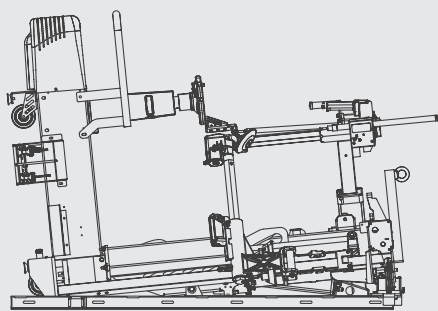

A

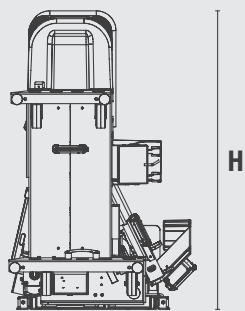

B

H

DATI TECNICI ARTIGLIO 50 / ARTIGLIO 55

range dimensioni ruota

diametro cerchio	da 12" a 30"
diametro max pneumatico	1200 mm (47")
larghezza massima pneumatico	15" (dal piano appoggio ruota)
pneumatici trattabili	convenzionali, low profile e Run Flat

autocentrante

bloccaggio	meccanico-manuale
motorizzazione	motoinverter 2 velocità
coppia di rotazione	1100 Nm
velocità di rotazione	7-18 rpm

stallonatore

campo massimo di stallonatura	670 mm
corsa stallonatore	540 mm
forza stallonatore	7600 N

carico/scarico ruota

azionamento	pneumatico
peso max ruota	85 Kg

alimentazione

elettrica 1Ph	230V-0.98 kW 50Hz/60 Hz
elettrica 1Ph (alternativa)	110V-0.98 kW 50Hz/60 Hz
pneumatica di esercizio	8 bar (minima)

peso	310 kg (con sollevatore)
-------------	--------------------------

TECHNICAL DATA ARTIGLIO 50 / ARTIGLIO 55

wheel dimension range

rim diameter	from 12" to 30"
maximum tyre diameter	1200 mm (47")
maximum tyre width	15" (from wheel supporting base)

tyre types processed	conventional, Low Profile and Run Flat
----------------------	---

turntable

clamping	mechanical-manual
drive system	2-speed motoinverter
rotation torque	1100 Nm
rotation speed	7-18 rpm

bead breaker

maximum bead breaking range	670 mm
bead breaker stroke	540 mm
bead breaker force	7600 N

wheel loading/unloading

operation	pneumatic
max wheel weight	85 Kg

power supply

electric 1Ph	230V-0.98 kW 50Hz/60 Hz
electric 1Ph (alternative)	110V-0.98 kW 50Hz/60 Hz
pneumatic operating pressure	8 bar (minimum)

weight	310 kg (with wheel lifter)
---------------	----------------------------

DIMENSIONI DI INGOMBRO - ARTIGLIO 50 OVERALL DIMENSIONS - ARTIGLIO 50

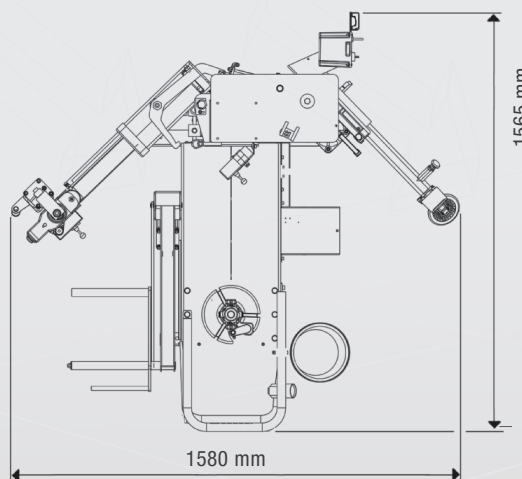
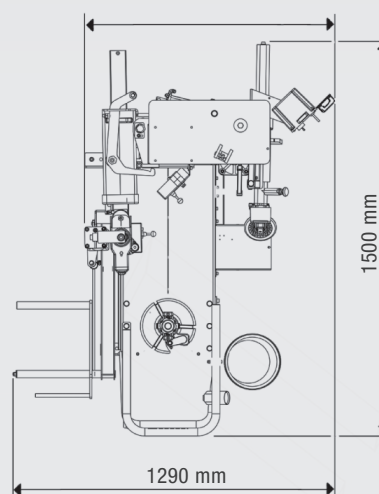
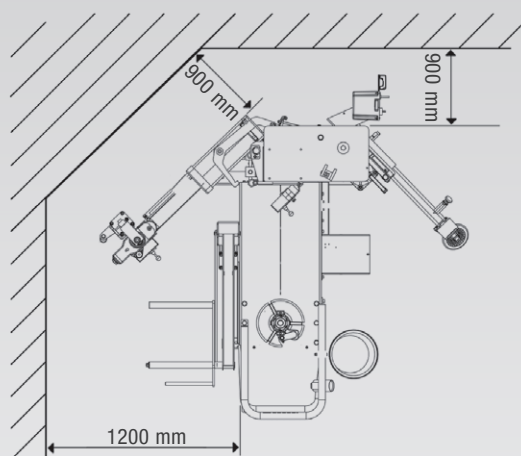

CORGHI S.p.A. a NEXION GROUP COMPANY
Strada Statale 468 n° 9 - 42015 CORREGGIO - R.E. - ITALY
Tel. ++39 0522 639.111 - Fax ++39 0522 639.150 - www.corghi.com - info@corghi.com



Per aiutare il pianeta ottimizzando il consumo di carta, i nostri cataloghi sono consultabili sul sito www.corghi.com. Una stampa responsabile aiuta a preservare l'ambiente.
To protect the planet and reduce paper usage, our catalogues are viewable online at the website www.corghi.com. Printing responsibly contributes to saving the environment.



Fotografie, caratteristiche ed i dati tecnici non sono vincolanti, possono subire modifiche senza preavviso.
The manufacturer reserves the right to modify the features of its products at any time.
Cod./ Code DPG0000657 - 04/2015