



# **artiGLio** *Master* **CODE**

FULLY  
AUTOMATED  
WORK CYCLES



# ARTIGLIO *Master* CODE

ARTIGLIO MASTER CODE continues in its constant evolution, faithful to the corporate mission of continuous innovation in products and technologies.

The new developments are designed to optimally meet the needs of wheel service specialists and anticipate the changing needs of the market. This is obviously possible thanks to the significant experience acquired by those who invented the tyre changer and to the numerous partnerships with rim and tyre manufacturers right from the design and testing phase of new technologies applied to the wheel.

MASTER CODE now has **4 automated work cycles** to make procedures increasingly fast, simple and absolutely safe for integrity of the rim and the tyre. The objective of these new and improved automatisms is to increase performance and efficiency with all wheel types and to reduce the use of that increasingly precious commodity - time. The computerised **Touch Screen** system guides the operator through all procedures and suggests the best possible solution to any problem encountered.

MASTER CODE is compatible with all tyre types, from Run Flat-UHP tyres to both small and large balloon tyres. With these features, together with the indispensable and exclusive demounting system, the Smart Corghi System, the MASTER CODE **rewrites the DNA of tyre changer systems**, confirming once again its inventors as the only people capable of driving the continuous evolution of the industry.

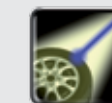

- 1 WHEEL DATA SELF-ACQUISITION
- 2 SMART CORGHI SYSTEM
- 3 DUAL BEAD BREAKER WITH CONTROLLED PENETRATION
- 4 AUTOMATIC LUBRICATION DIRECTLY ON THE BEAD
- 5 MOBILE CONTROL CONSOLE
- 6 INTERACTIVE TOUCH SCREEN
- 7 NEW INTELLIGENT ELECTROMECHANICAL TURNTABLE
- 8 INTEGRATED FULLY ARTICULATED LIFTER

- 9 TPMS DISPLAY
- 10 BEAD DEPRESSOR
- 11 LATEST GENERATION INVERTER MOTOR
- 12 "INFLATRON" ELECTRONIC INFLATOR
- 13 VIDEO CAMERA WITH IMAGE RECALLABLE FROM SCREEN AT ANY TIME DURING WORK
- 14 TREAD DEPTH PROBE
- 15 TYRE TEMPERATURE SENSOR
- 16 ERGONOMIC PEDAL CONTROLS

## 1 WHEEL DATA SELF-ACQUISITION

- self acquisition of wheel dimensions
- automatic tool positioning
- intelligent and very user friendly
- four wheel type settings
- quick
- safe
- ergonomic
- AUTOMATIC or MANUAL work cycle selection



interactive touch screen



Wheel data and automatic work procedure wizards



Automatic tool positioning for manual cycle

## 2 SMART CORGHI SYSTEM



- Smart Corghi System demounting procedure
- minimised tyre stress
- absolutely NO contact with rim!!!
- automated, synchronised tyre demounting and mounting

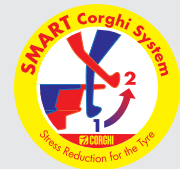

## 3 DUAL BEAD BREAKER WITH CONTROLLED PENETRATION

- dual pneumatic bead breaker penetrator
- maximum rigidity
- maximum efficiency and precision
- dual opposed bead breaker discs with separately controlled cylinders
- automatic repositioning of upper bead breaker arm



#### 4 AUTOMATIC DIRECT LUBRICATION



- automatic direct lubrication of lower and upper bead
- direct lubrication during dynamic bead breaking ensures maximum efficiency even with most stubborn tyres

#### 5 MOBILE CONTROL CONSOLE



total control in all manual operations

- freely adjustable mobile control console
- simple, quick and intuitive controls
- extreme user friendly manual cycle

#### 6 INTERACTIVE TOUCH SCREEN

- interactive multifunctional TFT-LCD TOUCH SCREEN interface with microprocessor control
- USB port for software databases update, and for loading files and videos
- playback capability for demonstration videos
- scheduled maintenance reminder, self-diagnosis, sensor state check and fault indication
- online help with instruction manual and special procedures (WDK, BSR, RFT, UHP)
- camera active during automatic work cycle



high degree of machine-operator interactivity



online help content display



video playback of any procedures inserted

#### 7 NEW INTELLIGENT ELECTROMECHANICAL TURNTABLE



- intelligent electromechanical turntable
- new patented wheel clamp system
- fast
- simple
- reliable for all wheel types (comes equipped with additional specific flanges)

## 8 INTEGRATED LIFTER

- integrated fully articulated lifter with 85 Kg max. load capacity



## 9 INTEGRATED TPMS

- for checking functionality of sensors and viewing important information



displaying sensor parameters and spare parts list



instrument for capturing sensor parameters

## 10 BEAD DEPRESSOR

- bead depressor with adjustable working height
- depressor shape ideal for RFT tyres
- WDK homologated



### 11 LATEST GENERATION INVERTER MOTOR

- second speed also available in reverse rotation mode
- torque control
- controlled acceleration curve to safeguard tyre



### 12 "INFLATRON" ELECTRONIC INFLATOR

- integrated, automated inflation and deflation system
- permits automatic inflation of tyre while operator performs other operations for optimised time use
- overpressure inflation for bead insertion
- touch screen user interface
- Bar, PSI and kPa scales
- end of cycle indicator

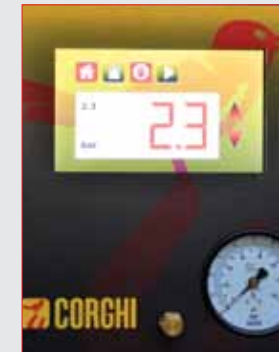

pressure setting



pressure reached

### 13 VIDEO CAMERA WITH IMAGE RECALLABLE FROM SCREEN



video camera activatable during operations, positioned for a clear view of the lower side of the tyre always active in the AUTOMATIC cycle

### 14 TREAD DEPTH PROBE



tread depth measurement



tread depth values: shown with yellow background to indicate values near minimum limit



tread depth values: shown with red background to indicate values below minimum limit

### 15 TYRE TEMPERATURE SENSOR (IN ACCORDANCE WITH WDK REQUISITES)



temperature measurement



20–25°C, green = work on tyre may proceed normally



15–19 and 21–30°C, yellow = proceed with caution



<15 and >30°C, red = do not work on tyre

- real-time tyre and bead temperature sensor
- maximum measurement speed and precision (resolution 0.1°C), with value displayable in Centigrade or Fahrenheit
- intuitive colour-based temperature indication in accordance with WDK requisites for working with RFT and UHP tyres

## TECHNICAL DATA

Wheel dimension range	rim diameter	from 13" to 32"
	maximum tyre diameter	1200 mm
Technical features	clamping	automatic
	drive system	2-speed inverter motor
	torque	1200 Nm
	rotational speed	7-20 rpm
Bead breaking	maximum bead breaking range	19"
	upper bead breaker force	7300 N
	lower bead breaker force	7300 N
Touchless demounting/mounting tool set		
Wheel lifter load capacity		85 Kg
Power supply	electric 1Ph	230V-0.98 kW 50Hz/60 Hz
	electric 1Ph (alternative)	115V-0.98 kW 50Hz/60Hz
	pneumatic operating pressure	8 to 10 bar
Weight		595 Kg

The manufacturer reserves the right to modify the features of its products at any time.

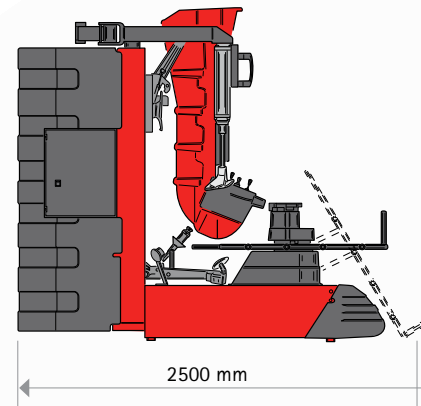
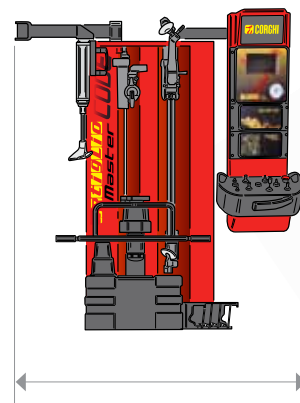
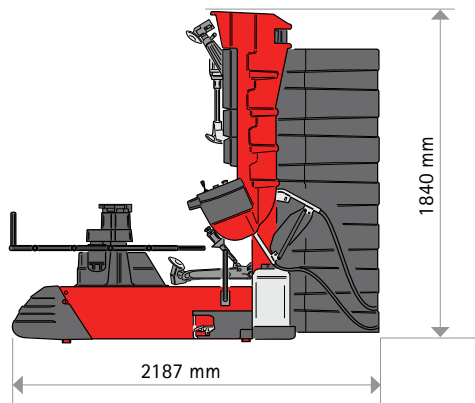

## VERSIONS

	Lifter	Bead depressor	Lubricator	Video camera	Inflatron	TPMS	Tread probe	Temperature sensor
BASE	•	•						
SLIDE	•	•	•					
VISUAL	•	•		•	•			
VISUAL L	•	•	•	•	•			
INSPECTION	•	•				•	•	•
INSPECTION L	•	•	•			•	•	•
COMPLETE	•	•	•	•	•	•	•	•



To protect the planet and reduce paper usage, our catalogues are viewable online at the website [www.corghi.com](http://www.corghi.com). Printing responsibly contributes to saving the environment.

P/N DPCG000380B - 05/2013



CORGHI S.p.A. a NEXION GROUP COMPANY - Strada Statale 468 n° 9 - 42015 CORREGGIO - R.E. - ITALY  
Phone +39 0522 639111 - Fax +39 0522 639150 - [www.corghi.com](http://www.corghi.com) - [info@corghi.com](mailto:info@corghi.com)