

**HD 900**

**60**<sup>of</sup>  
**TECHNOLOGY**  
CORGHI



**Smontagomme elettroidraulico**



**Electrohydraulic tyre changer**



**Elektrohydraulische Reifenmontiermaschine**

**CORGHI**  
seguì Corghi - follow Corghi

# HD 900



## SMONTAGOMME ELETTRIDRAULICO

per pneumatici di autocarri, autobus, trattori e veicoli di movimentazione terra, con cerchi a canale o ad anello elastico e per pneumatici con o senza camera d'aria.



## ELECTROHYDRAULIC TYRE CHANGER

for trucks, buses, tractors and earth moving equipment with groove or elastic ring type rim wheels and with tubeless or inner tube type tyres.



## ELEKTROHYDRAULISCHE REIFENMONTIERMASCHINE

für Reifen von LKWs, Autobussen, Traktoren und Erdbewegungsmaschinen mit Tiefbett- oder Sprengringfelgen und für Schlauchreifen und schlauchlose Reifen.

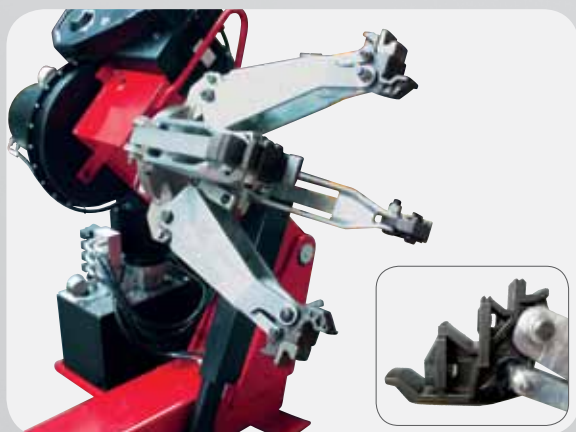

- 1 Mandrino autocentrante con rotazione oraria ed antioraria a due velocità. 1 Turntable with two-speed rotation both clockwise and anticlockwise. 1 Spannteller mit Drehrichtung in und gegen den Uhrzeigersinn und mit zwei Geschwindigkeiten.



**2** Manipolatore con comandi ergonomici. **2** Control module with ergonomic controls. **2** Bediensäule mit ergonomischen Bedieneinrichtungen.

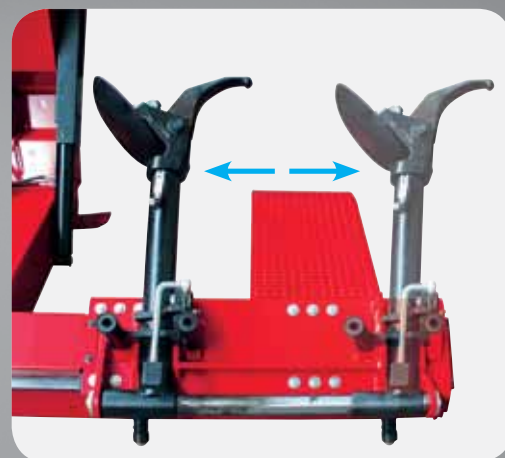

**3** Carrello con movimento idraulico destra-sinistra e braccio utensile con sistema di bloccaggio di sicurezza. **3** Carriage with hydraulic left-right translation and tool arm with safety lock system. **3** Werkzeugschlitten mit hydraulischer Rechts-Links-Bewegung und Werkzeugarm mit Sicherheitsblockiersystem.



**4** Centralina idraulica. **4** Hydraulic power unit. **4** Hydraulikaggregat.

**5** HD 900 è in grado di operare su ruote fino a 1000kg. **5** HD 900 can work with wheels weighing up to 1000kg. **5** HD 900 kann mit Rädern von bis zu 1000kg arbeiten.



**6** Griffe speciali per cerchi in lega con inserti in plastica (a richiesta). **6** Special clamps with plastic insert for alloy rims (optional). **6** Spezialspannklauen für Leichtmetallfelgen mit Plastikeinsätzen (auf Anfrage).

DATI TECNICI	TECHNICAL DATA	TECHNISCHE DATEN	
Larghezza max. ruota	Max wheel width	Max. Radbreite	1065 mm
Diametro max. ruota	Max. wheel diameter	Max. Raddurchmesser	2300 mm
Capacità della morsa	Chucking device capacity	Spannbereich	14" ÷ 46" (PA = 56")
Motore centralina idraulica	Hydraulic unit motor	Motor Hydraulikaggregat.	1,5 kW
Motoriduttore a due velocità	2 speed gear box motor	Getriebemotor mit zwei Geschwindigkeiten	1,3 ÷ 1,8 kW
Capacità cilindro sollevamento ruota	Max. wheel lifter cylinder capacity	Hubkraft Hubzylinder Rad	1600 kg
Peso max. ruota	Max. wheel weight	Max. Radgewicht	1000 kg
Voltaggio	Voltage	Spannung	230/400 V 3ph 50/60 Hz
Peso	Weight	Gewicht	762 kg

• **ACCESSORI STANDARD** • **STANDARD ACCESSORIES**  
 • **STANDARDZUBEHÖR**



• **ACCESSORI CONSIGLIATI** • **RECOMMENDED ACCESSORIES**  
 • **ZUBEHÖR EMPFOHLEN**

**A.** Anelli di protezione per cerchi in lega - Alloy protection ring -  
 Radschutz für Alu-felgen

- Ø 161 mm 8-12100007
- Ø 164 mm 8-12100005
- Ø 176 mm 8-12100006
- Ø 202 mm 8-12100008
- Ø 220 mm 8-12300001
- Ø 221 mm 8-12100009
- Ø 281 mm 8-12100010

**B.** Rullo tubeless per gomme da camion e autobus -  
 Tubeless tyre roller for truck and bus wheels -  
 Montierrolle für schlauchlose Lkw- und Busreifen 2306040

**C.** GL Nuove griffe speciali per cerchi in lega con  
 inserti in plastica - GL New special clamps with  
 plastic inserts for alloy rims. - GL Neue Aufsatzbacken  
 für Leichtmetallräder mit Kunststoffeinsätze 8-12100156

**D.** DV 120 Premitalone pneumatico con comando  
 manuale a leva. - DV 120 Lever-operated  
 pneumatic bead presser - DV 120 Pneumatischer  
 Wulstniederhalter mit Handhebelbedienung 0-12100701



• **DIMENSIONI DI INGOMBRO**  
 • **OVERALL DIMENSIONS**  
 • **ABMESSUNGEN**

	min	max
<b>H</b>	<b>970</b>	<b>1550</b>
<b>L</b>	<b>1980</b>	<b>2450</b>
<b>P</b>	<b>1700</b>	<b>2300</b>

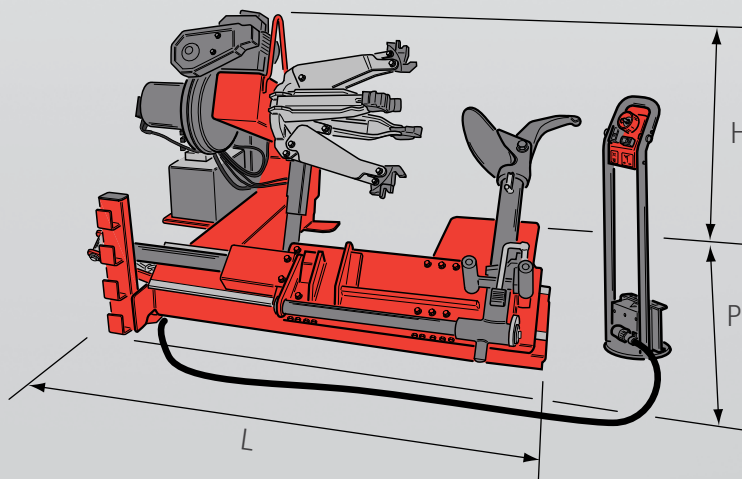

Fotografie, caratteristiche ed i dati tecnici non sono vincolanti, possono subire modifiche senza preavviso. The manufacturer reserves the right to modify the features of its products at any time. Les photographes, les descriptions et les données techniques ne sont pas contraignantes. Le fabricant se réserve le droit d'apporter des modifications sans préavis. Die Fotografien, die angegebenen Eigenschaften und die technischen Daten sind nicht verbindlich und können ohne Vorankündigung geändert werden. Fotos, características y datos técnicos no son vinculantes, pueden estar sujetos a modificaciones sin previo aviso. As fotografias, as características e os dados técnicos não são vinculantes, podem ser modificados sem prévio aviso. Code: DP6000576 04/2014

Per aiutare il pianeta ottimizzando il consumo di carta, i nostri cataloghi sono consultabili sul sito [www.corghi.com](http://www.corghi.com). Una stampa responsabile aiuta a preservare l'ambiente. To protect the planet and reduce paper usage, our catalogues are viewable online at the website [www.corghi.com](http://www.corghi.com). Printing responsibly contributes to saving the environment.

